

Unified Workflow of APC Request Packages – PHASE I

Revised 01/23/09

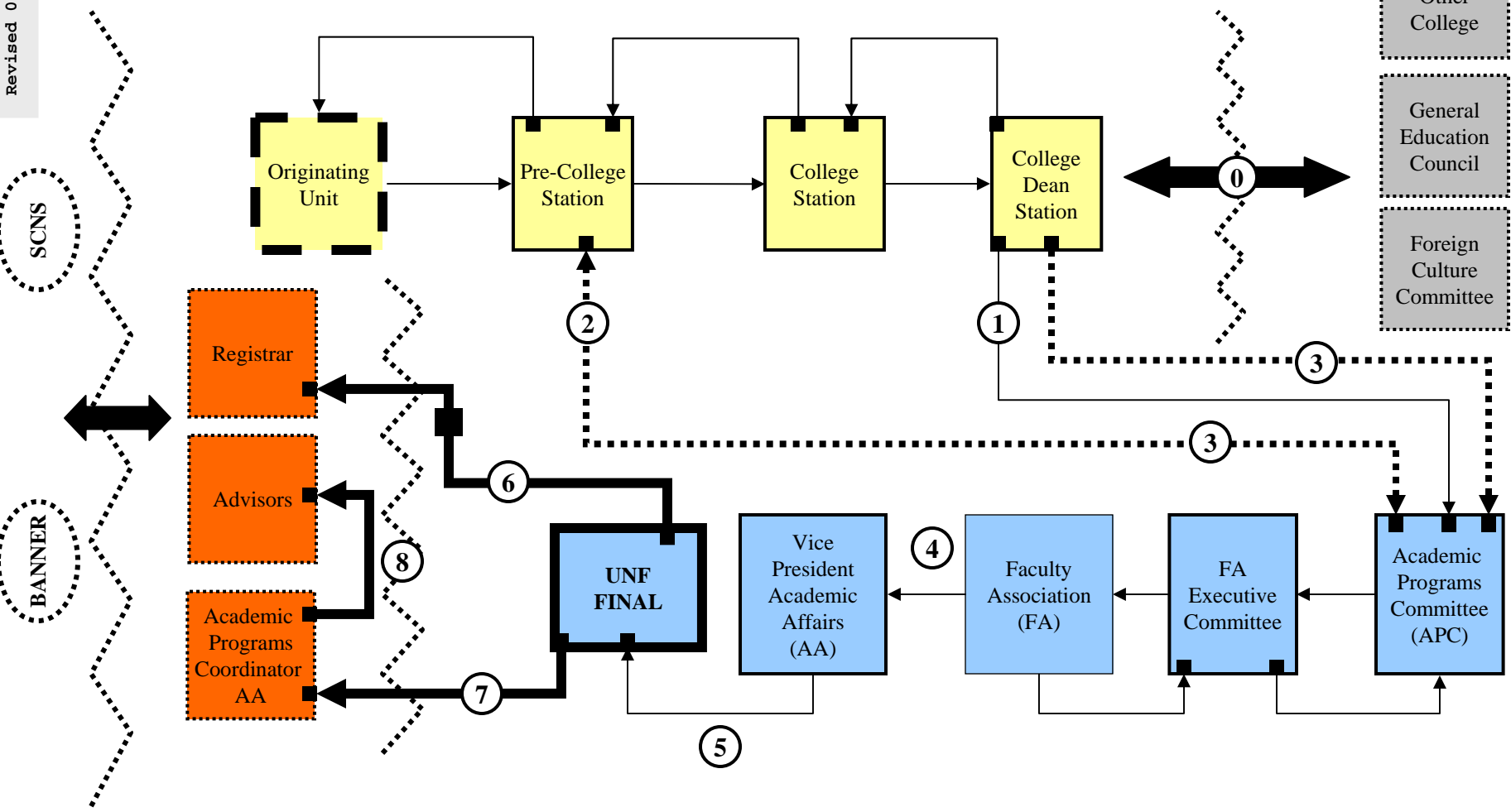

Transitions:			Stations/Consumers:			Others:			Legend	
	Forward prior APC		Review within College		Boundary		Interoperation		Annotation	
	Backward (revision) prior APC		Begin/Initial St.		Review as Needed		External System		Ext. Entity	
	Backward (revision) after APC		End/Final St.		Review by Fac. & Adm.		Connector			
	Forward after APC		Ext. Consumers							

Annotations - The order is important+

Off-line communication
NOT implemented by the
workflow system

①

Deans communicate with external entities, as needed, off-line. External entities communicate decisions via comments on the appropriate package(s).

②

Deans transition the package once it has been reviewed by other entities (gray) as needed. Typically this happens on the first iteration when the package is created by the originating unit.

③

The package is transitioned APC-to-Pre-College-Station when the package is found to be incomplete when received at the APC station.

④

The package is transitioned Pre-College-Station-to-APC when the package has been modified as requested by the APC. It could also be forwarded by the Dean, the second time around.

⑤

At this point the package has been approved by the UNF Faculty and the “signature” of the Provost and VP for Academic Affairs is required.

⑥

The package is forwarded with the “signature” of the Provost and VP for Academic Affairs to the final station.

⑦

Information in the package is used by the Registrar to communicate with external systems such as Banner and SCNS. In the current business process, only the information related to APC forms 1 and 2 are sent to the registrar.

⑧

Information in the package is used by the office of the Provost and VP for Academic Affairs (AA) to set up what in the current business process is related to APC form 3.

⑨

Information in the package is used by Advisors (currently on the APC 3 forms). AA needs to know when advisors acted on such information.

To be implemented
by external systems
(not the workflow system)
which uses the DB maintained
by the workflow system

+ This means the transition numbered i happens before the transition numbered j when $i < j$