

DESIGN, FABRICATION, AND IMPLEMENTATION OF JUMP-CUE TESTING MACHINE

Joe Lewandowski
Research Assistant
University of North Florida

Ivan Faustino
Engineer
JEA (Jacksonville Electric
Authority)

Daniel Cox
Associate Professor
University of North Florida

ABSTRACT

A device for measuring the effectiveness of a jump cue performing the jump shot in the game of pool is presented. The design, build, integration, and current application of the jump-cue testing machine are described. A physical system model is described that allows for the basic actuation of the mechanical system to be established and understood. The mechanical design embodiment of the jump-cue testing machine is presented with mechanical design and realization aspects of the device emphasized. Examples of current use of the jump-cue testing machine by industry are described.

INTRODUCTION

Mechatronics is the design and integration of mechanical, electronic, sensor, and computer technologies into intelligent systems. A pool cue design and manufacturing client, Predator Products, Inc. of Jacksonville [1] has several applications for which mechatronics can be applied. Predator Products, Inc. is a world-class supplier of pool cues with a majority of the top professionals using their products. Their products include an array of cues including pool cues for shooting, break cues, jump cues, billiard cues, as well as other specialized cues. Therefore, the company desires devices that can test and demonstrate the superior performance of their products. Undergraduate Mechanical Engineering students are working on these mechatronics application projects.

Mechatronic devices have been developed for application in the pool cue industry. This includes the design of a pool-playing robotic device [2] and a device for measuring the effectiveness of a break shot occurring in a game of pool [3]. These devices incorporate the integration mechanical, electronic, and computer software into a mechatronic system.

In this project, the client desires the machine to measure the effectiveness of a jump cue. There are several reasons the client wants this type of machine; first, the company is designing and manufacturing a pool cue designed specifically for the “jump shot” (as opposed to a standard shooting cue). A jump shot occurs when the player wants to shoot the cue ball such that the cue ball jumps over another ball on a trajectory aimed at the target ball. Thus, the usefulness of the jump-cue testing machine helps demonstrate that a jump cue performs better under the capability of a repeatable shot. Another reason the company desires the machine is to provide a jump-cue testing machine to improve the effectiveness of the design process for the jump cue itself. Many options exist for the shape and mass distribution of a jump cue; therefore it is useful

to obtain empirical results for the various design options and configurations of jump cues.

This paper describes progress and accomplishments on the development of the jump-cue testing machine. Following the design objectives, the design of the physical machine is next described. The build (component selection and custom fabrication) and integration of the jump-cue machine is presented. A basic model for the actuation and an example application for the use of the jump machine are then presented. In the conclusion, current project status and future work are discussed.

NOMENCLATURE

KE	kinetic energy
PE	potential energy
m	mass of jump cue and carriage
k	spring constant
v	velocity of jump-cue

BACKGROUND

The client desires a jump-cue testing machine that is able to shoot the same jump shot with a high degree of repeatability. This enables the client to demonstrate the performance of their jump cue compared to another in a consistent, repeatable manner. In the application of the jump-cue testing, a machine with ability to shoot the same shot with a high degree of repeatability also facilitates the research and development process. Rapid setup for jump-cue testing is therefore an important attribute of the machine. For research and development of jump cues, many experiments must be performed to obtain empirical data, thus the machine must be easy to use to allow for rapid data collection.

DESIGN OBJECTIVES

The jump-cue testing machine has two high-level design requirements directly related to the two primary reasons that the client would like to have the device developed. 1) Design the jump-cue testing machine to be easily used in an applied research and development setting, 2) design the jump-cue testing machine as a performance measurement tool to measure the performance of various jump cues designed for jump shots.

With an initial understanding of the parameters for a basic mechanical design, the design of the jump-cue testing machine is developed considering a variety of alternatives. Several ideas have been considered and several prototype versions of the

machine have been initially developed. It is apparent that ease of use is a salient design feature. A basic concept for the jump-cue testing machine is shown in Figure 1. The device is designed to have three degrees of translational adjustment (X, Y, and Z axes), and one degree of freedom in rotation to adjust the angle of attack for the jump shot.

The actuation and energy transfer within the machine occurs with springs. A translating carriage (see Figure 1) is attached to an adjustable platform. The carriage is spring loaded to the platform. Adjustment of the spring force occurs by cocking the spring actuator, through a pneumatic system, and locking it with a trigger. To accomplish a jump shot, the trigger is released. Ease of use attributes, in addition to the adjustability, are ease of set-up for test runs. Due to the large spring forces generated, the actuator is loaded with the assistance of a pneumatic actuator.

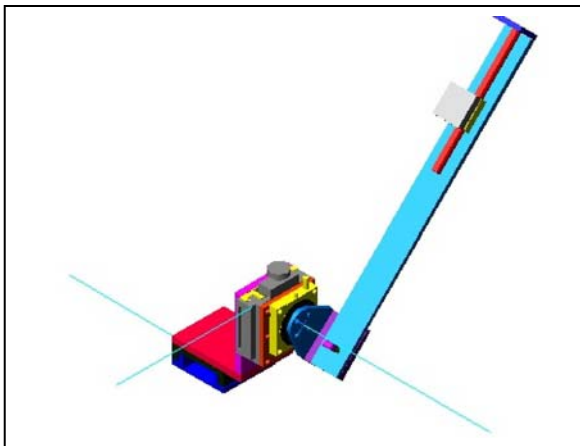

Figure 1. Design Concept for Jump-Cue Test Machine

With the basic concept outlined, the build and implementation phase for the jump-cue testing machine is discussed next.

BUILD OF JUMP-CUE TEST MACHINE

The requirements set by the client; Predator Products, Inc. of Jacksonville for the jump-cue testing machine as shown in Figure 2 establishes three major categories for design and build features.

The first feature requirement is the machine has to be portable, yet the base has to be fixed during the operation of the jump-cue machine. This is accomplished by mounting 1.5 inch thick hard wood to the top a portable tool chest. The base of the jump-cue testing machine is then mounted with 0.5 inch bolts to the hardwood. This base design allows the jump machine to be moved around the billiards table to any location, and then the wheels of the tool chest are locked in place for stability during operation



Figure 2. Jump-cue Testing Machine

To help with the stability of the back end of the machine's arm, a three foot lead screw is mounted to the arm's square tubing. This helps support the pneumatics and bearing at the end of the arm, and allows height adjustment during the different angle shots. The lead screw can be seen supporting the jump-cue machine also shown in Figure 2.

The second feature requirement of the jump-cue testing machine is the machine has to adjust for angle of attack from 15° shot to a 90° shot, or directly above the cue ball. This is accomplished with the dial rotary bearing seen in Figure 3. The dial rotary bearing allows the user to adjust the pitch of the machine's arm within the degree limits set. While the machine's arm changes from, for example, 30° to 60°, the tip of the machine's arm gets further from the table because it is rotating around the fixed axis of the dial bearing. To eliminate this problem, the square tubes of the machine's arm are allowed to slide through the frames supporting them as seen in Figure 3. Once the desired distance from the table to the tip of the machine's arm is set, a set screw is tightened to secure the position. The alignment of the tip of the jump cue to the ball can also be adjusted using the linear bearings on the base. These three bearings allow for translational adjustment in the X, Y, and Z directions.

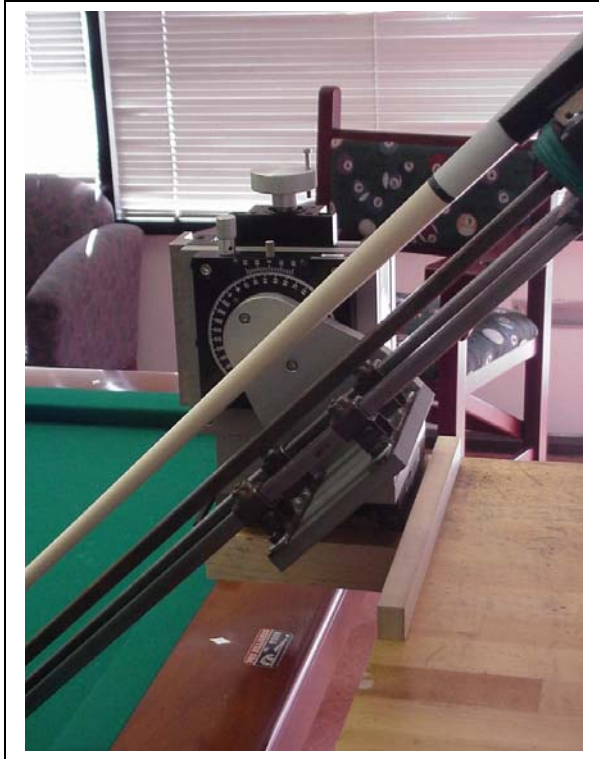

Figure 3. Angular Adjustment for Jump Shot

Figure 4 shows the adjustable bearings in the translational adjustment (X, Y, and Z axes).



Figure 4. Jump-Cue Testing Machine Front View

The third major feature requirement is the machine has to accelerate the jump cue enough to allow a jump shot to occur.

This is done with two springs along the rod for the slider bearings attached to the plate supporting the butt of the jump cue. As the jump cue is pulled back, the slider bearing compress the two springs. Once the desired stroke is reached and the cue ball is in place, the plate supporting the butt of the jump cue is released, and the spring force accelerated the jump cue toward the ball.

The industrial springs are extremely stiff. Therefore, a pneumatic Parker bearing is mounted under the sliding plate. To pull back the machine, a trigger mounted to the pneumatic Parker cylinder attaches to an eye bolt on the back of the sliding plate supporting the jump cue. The operator activates a simple I/O controller to allow air pressure to pull back the sliding plate. The pneumatics serves two functions. The first is to give a non-labor intensive way to load the machine making it very easy to use, and the second is to allow a way to control the spring force applied to the sliding plate. A regulator at the inlet of the cylinder controls the air pressure used to load the machine. By gauging the air pressure and surface area of the piston in the cylinder, the force pressing against the spring resistance is known. This eliminates the need to measure the distance the spring is compressed during each shot. Finally, to start the shot, the trigger is tripped, the sliding plate is released, and the two industrial springs accelerate the jump cue toward the ball. The guide seen in Figure 5 maintains the correct path for the jump cue. It utilizes four elastic straps to guide the cue. Because the jump cue is tapered, elastic is used to allow for a secure guide throughout the entire length of the stroke.

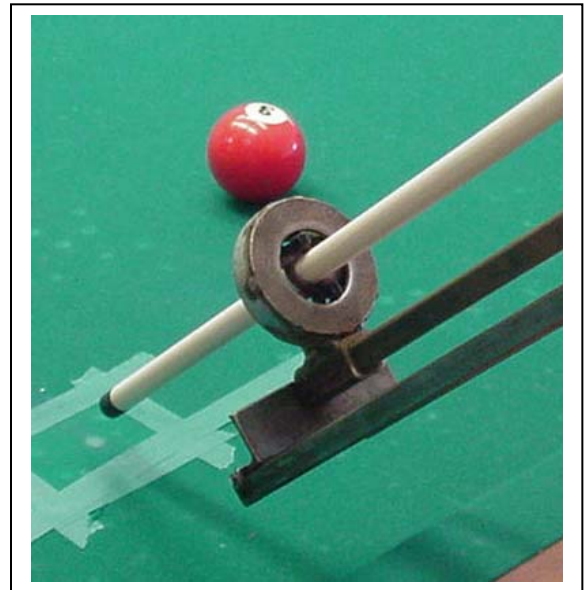

Figure 5. Guide for Jump Cue

BASIC MODEL FOR JUMP-CUE ACTUATION

A basic model of the jump-cue testing machine is presented using the conservation of energy. The change in kinetic energy of the jump cue can be expressed as follows:

$$\Delta KE = \Delta PE_{spring} \quad (1)$$

With the potential energy to actuate the carriage with the jump cue attached stored in the spring. Here potential energy associated with height is negligible compared to the energy content of the spring,

$$\Delta PE = \frac{k(\Delta s)^2}{2} \quad (2)$$

The kinetic energy, once the spring is released is

$$\Delta KE = \frac{m(\Delta v)^2}{2} \quad (3)$$

Friction between the bearing and the rails is assumed negligible for this calculation. Substituting equations (2) and (3) into equation (1) gives:

$$\frac{m(\Delta v)^2}{2} = \frac{k(\Delta s)^2}{2} \quad (4)$$

Solve equation (5) for Δv :

$$\Delta v = \sqrt{\frac{k(\Delta s)^2}{m}} \quad (5)$$

With $v_o = 0$, before the trigger is released. Therefore,

$$v_f = \sqrt{\frac{k(\Delta s)^2}{m}} \quad (6)$$

gives the final velocity of the carriage, with the jump cue attached. This velocity can be used in more complex models of impact between the jump cue and the cue ball.

With the transfer of energy from the spring, an estimate of the final velocity of the jump cue is possible., knowing its mass, the mass of the carriage, and the spring constants. This model is to be used to quantify the parameters of the jump-cue testing procedures. As a priority, the client is primarily interested in obtaining empirical results using the jump-cue testing machine. The machine's repeatability to compare commercially available jump cues and to those in product development satisfies the current and immediate needs.

EXAMPLE OF IMPLEMENTATION

The initial uses for the jump-cue testing machine occurs in two phases. The first phase is to test, compare, and rank the

leading jump cues being sold on the market today. The second phase is to test a prototype jump cue for baseline data, and then test and document the changes in the prototype's performance as modifications are made to the prototype.

The first phase requires the acquisition of all leading jump-cues on the market today for tests and evaluation. The jump cues are tested and ranked on both qualitative and quantitative properties. The ease a jump cue jumps the cue ball is qualitatively measured for each jump cue. Some jump cues have a large target area where it strikes the cue ball while others require more precision where the cue's tip hits the ball. The jump cues would not jump the ball unless the tip hit the exact location on the cue ball. Both the jump distance and jump height are quantitatively measured and documented for all the jump-cues. To measure the jump distance, carbon paper is laid on the table in the direction of the trajectory of the cue ball. When the cue ball landed on the carbon paper, a landing mark is made. The distance from this mark to the initial placing of the ball is measured. It is decided by the client that it is not important to actually find the maximum height of the cue ball's trajectory. Instead, it is important to know how quickly a jump-cue could elevate a cue ball over another ball. This is quantified by incrementally placing a ball closer to the cue ball prior to the jump. The closest distance a ball could be to the cue ball without the cue ball touching it during the jump is measured. This measurement gives the manufacturer a value which is compared to all the other jump-cues tested of which jump-cue elevates the cue ball the quickest.

During the first phase of the jump-cue testing the client has become more familiar with how well the machine works. A main ease of use attribute of the jump-cue testing machine is the ability of the machine to adjust many different ways, not only to the different angle of attack, but also to the different sizes of jump-cues being tested. The adjustment on the base in the X, Y, and Z directions allow the operator to align the jump-cue precisely for each trial. This is extremely important with jump cues that require more precision as they strike the cue ball during a jump shot. The radial adjustment used initially allows testing of all the cues at 30°, 45°, and 60°. By testing the jump-cues at different angles, trends are noticed about the construction of the different cues. Qualities in some cues allowed them to jump consistently and precisely during high angle shots, while other qualities allowed for distance during low angle shots. Based on the data, the client has decided that two jump cues could be developed; one for short, high precision shots and another for long, full table shots.

From the data collected in the first phase of implementation, requirements are set for the development of the new jump cue. After jumping and testing all the jump cues in the market, the client has discovered proprietary theories of what properties the new jump-cue should have. This information is used in product development of a prototype for the next generation of jump cue with the desired properties.

The second phase of implantation is to test the new jump cue prototype in the same manner as the jump-cues have been tested previously. Once baseline data is obtained, small changes have been made to the jump cue to observe and improve performance. Again, the accuracy and precision of the jump-cue testing machine is crucial to ensure the data logged could be fairly compared to other jump cues or other variations within the jump cue prototype.

SAMPLE OF EXPERIMENTAL RESULTS

During the first phase of the jump cue machine's implementation, 18 popular jump cues are tested. The jump cues are ranked according to jump distance, jump height, accuracy, and ease of jump. Table 1 shows the results from Jump Cue X's preliminary jumps.

Jump Cue X

SHOT	Total	Clearance
	Distance (in)	Length (in)
1	36.00	5.875
2	36.50	5.875
3	36.75	5.875
4	37.75	5.875
5	39.50	6.00
6	39.75	6.00
7	39.75	6.00
8	40.25	6.00
9	40.25	6.00
10	41.50	6.125
AVG.	38.80	5.96
RANGE	5.50	0.25
STD.	1.89	

Table 1. Jump results for Jump Cue X

From the results, one can see that the jump cue machine was able to reliably jump a cue ball during the experiment, and all 10 jumps landed within a 5.50" range. The reliability of the machine is critical if the results from one experiment are to be compared to the results from another jump cue's experiment.

The "Total Distance" column gives the distance the cue ball jumped across the table. As described before, carbon paper was laid on the table, and therefore a dot was made where the cue ball landed. The distance from the center of the ball prior to the shot to the dot created on the carbon paper gives the "Total Distance." The "Clearance Length" is the distance from the center of the cue ball prior to the shot to the center of another ball in the path of the shot. The other ball is incrementally moved closer to the cue ball until it is hit by the cue ball during the shot. This distance lets one understand how quickly a jump cue can jump a cue ball off the table. The smaller the "Clearance Length" is, the closer a ball can be to the cue ball during a jump without the cue ball hitting it during the trajectory of the jump.

The results from Jump Cue Y are shown in Table 2. The performance of the two jump cues can now be compared. In the category of "Total Distance," one can see that Jump Cue Y clearly can jump the ball further than Jump Cue X. This extra distance usually comes with a price. The standard deviation increases as the average jump length increases. This was seen on all 18 of the jump cues tested. Realizing that the short

jumps are relatively more accurate than the longer jumps, led Predator to start developing both a short distance jump cue and a long distance jump cue. Both Jump Cue X and Jump Cue Y are very easy cues to jump. This is a qualitative remark from our experiment. Both jump cues had a large area on the cue ball which could be struck to cause the cue ball to jump.

Jump Cue Y

SHOT	Total	Clearance
	Distance (in)	Length (in)
1	61.00	5.00
2	62.75	5.00
3	63.00	5.10
4	63.50	5.10
5	63.50	5.10
6	64.50	5.125
7	64.50	5.125
8	65.50	5.125
9	66.50	5.30
10	68.00	5.30
AVG.	64.28	5.13
RANGE	7.00	0.30
STD.	2.01	

Table 2. Jump results for Jump Cue Y

The "Clearance Length" of Jump Cue Y was shorter than the "Clearance Length" of Jump Cue X. This means that a ball can be closer to Jump Cue Y than Jump Cue X during a jump and will not be hit during the jump. One can see that the trend in the data shows that as the "total distance" goes up, the "Clearance Length" also goes up. This is due to the slight change in the cue ball trajectory. The longer jumps have a relatively flatter trajectory and therefore require more distance to elevate above the height of the ball in its path. The shorter jumps have a higher trajectory, and therefore quickly elevate above the ball in its path.

CONCLUSION AND FUTURE WORK

This paper has described progress and accomplishments on the development of the jump-cue testing machine. The design and build of a jump-cue testing machine for measuring the effectiveness of a jump cue occurring for the jump shot in a game of pool has been presented. A basic physical system model of the actuation system has been described. The mechanical design concept and realization aspects of the device have been discussed. Examples of current use of the jump-cue testing machine as currently being used by the project sponsor have also been discussed.

The jump-cue testing machine has been used extensively for the comparison of jump cues. The jump cues commercially available have been tested and an increased understanding

design attributes of these cues has been made possible by using the jump-cue testing machine to produce repeatable jump shots. With this understanding, product development of the client's jump cue product offerings has progressed. The basic model for the actuation system will be used to improve the understanding of jump cue modeling and interaction with the cue ball and quantify the dynamics of the jump shot.

ACKNOWLEDGMENTS

The authors gratefully acknowledge the support and funding by Predator Products for this project.

REFERENCES

[1] <http://www.predatorcues.com>

- [2] Pombier, P., Wider, W., and Cox, D., "Mechatronic Device to Measure Break Shots", ASME Southeastern Region XI Technical Journal Volume 2, Number 1, pp. 3.1-6, April 2003.
- [3] Williams J., Wider, W., and Cox, D., "Pool-Playing Robot Design Project", ASME Southeastern Region XI Technical Journal Volume 3, Number 1, pp. 7.1-8, April 2004.
- [4] Faustino, I., Lewandowski, J., and Cox, D., "Design and Build of Jump-Cue Testing Machine", *submitted to ASME Southeastern Region XI Technical Journal*.